

VERA TEST PROTOCOL

Covers and other Mitigation Technologies for Reduction of Gaseous Emissions from Stored Manure

Version 3:2018-07

Foreword

To meet the environmental challenges in livestock production, new technologies are being developed within EU member states and elsewhere. These so-called environmental technologies are designed to potentially enhance the eco-efficiency of livestock production by reducing material inputs, emissions of pollutants and energy consumption, in addition to recovering valuable by-products and minimising waste disposal problems. Environmental technologies in agriculture can be introduced in different stages of the production chain, e.g. techniques applied in animal houses or techniques for manure storage, processing, or land application.

However, central stakeholders, such as farmers and authorities, only have limited information about the performance of these technologies, which hampers their diffusion in the agricultural sector. The Danish Ministry of Environment, the Dutch Ministry of Infrastructure and Environment, the German Federal Ministry of Food and Agriculture and the German Federal Environment Agency, in cooperation with the international technical experts, have therefore begun the development of common test protocols for the testing and verification of such environmental technologies for agricultural production. The VERA test protocols are designed to investigate the environmental performance and operational stability of a technology, thus providing reliable and comparable information about the performance of technologies to farmers, authorities, and other stakeholders.

This initiative has been organised by VERA – Verification of Environmental Technologies for Agricultural Production. The VERA collaboration was established in 2008 to promote an international market for environmental technologies for agricultural production. The overall purpose of VERA is to fill the information gap for the key stakeholders by offering independent verification of the environmental performance and operational stability of environmental technologies, determined by applying specific VERA test protocols.

The first version of the Protocol for Covers and other Mitigation Technologies for Reduction of Gaseous Emissions from Stored Manure was finalised in 2009, the second version in 2013. The present version 3 was published in July 2018.

Questions and comments on the VERA test protocols should be sent to

International VERA Secretariat
www.vera-verification.eu
info@vera-verification.eu

Amendments

This edition of the VERA test protocol has been thoroughly revised to reflect the latest state-of-the-art, and differs from the earlier version 2 (2013) as follows:

- a. The order of sections has been modified to be uniform for all VERA test protocols and to be consistent with the VERA basic structure for test reports. The general format and structure of the documents have been harmonised using a new 'high level structure'. This should help the user to navigate through the documents and bring them closer to the format of an international standard.
- b. The requirements and recommendations are more precisely indicated, especially for the description of sampling and testing certain parameters, e.g. minimum dimensions for both liquid and solid storages, description of the use of dynamic chambers, including examples in the Annex.
- c. In order to keep the option of a verification on odour in this protocol, measurements can be performed according to the VDI 3880. However, this might be accepted only by German authorities, and may not be in other countries. As soon there are more precise measurement methods available, these should be used.

Previous editions

VERA Test Protocol for Covers and other Mitigation Technologies for Reduction of Gaseous Emissions from Stored Manure, Version 2:2013-06

VERA Test Protocol for Covers and other Mitigation Technologies for Reduction of Gaseous Emissions from Stored Manure, Version 1:2009-12

Table of Contents

1. Introduction	6
2. Scope	6
3. Normative references	7
4. List of abbreviations	8
5. Terms and definitions	9
6. System description	11
7. Requirements	13
7.1 Pre-testing or preparations for a full test of a technology.....	13
7.2 Responsibilities during test period	13
7.3 Test design and sampling strategy	14
7.3.1. Test design.....	14
7.3.2. Sampling strategy	14
7.4 Measurements.....	16
7.4.1 Calibration, verification and validation.....	16
7.4.2 Measurement parameters	16
7.4.3 Measurement methods.....	18
7.5 General aspects	19
7.5.1 Permitted deviation from the protocol	19
7.5.2 Regulations, occupational health and safety.....	19
7.6 Data treatment, calculation and evaluation of emissions	19
8. Test report and evaluation	20
9. Bibliography	22
Annexes	23
Annex A (informative): Template for a test plan	23
Annex B (informative): Examples of dynamic chambers.....	25

List of tables

Table 1: System description of covering systems	11
Table 2: System description of manure treatment systems.....	11
Table 3: Sampling strategy during test of environmental storage technologies	14
Table 4: Sampling requirements, if only partly covered	15
Table 5: Composition of the livestock manure used in the test.....	15
Table 6: Environmental and weather conditions during sampling	15
Table 7: Sampling/ measuring methods for the measurement parameters ammonia, odour and GHG.....	17
Table 8: Selection of methods for the respective storage types.....	19

List of figures

Figure 1: Dynamic chamber with plate	25
Figure 2: Dynamic chamber with narrow inlet	25
Figure 3: Dynamic chamber with elevated air inlet	26
Figure 4: Dynamic chamber with air flow straightener.....	26

1. Introduction

The objective of this protocol is to specify the test procedure for the environmental effects of covers and other mitigation technologies for reduction of gaseous emissions from stored manure. This includes definitions, specific requirements and conditions for testing, measurement and sampling methods, processing and interpretation of measurement results and reporting specifications. More general requirements for the parties involved in the test, and the individual process steps for testing and verification, are laid down in the 'General VERA Guidelines', which were approved by the International VERA Board.

This document was elaborated by nominated international experts of the 'International VERA Expert Commission' (IVC) for covers and other mitigation technologies.

The aim of the VERA verification statements is that their information can be optimally used by different stakeholders in the member states. This means that the test protocol should provide a broad array of reliable information that can be analysed and summarised during the verification in such a way that the outcome of the test can be used, directly or indirectly, as widely as possible by the different international users.

However, for reasons of costs and time, the test protocols have restrictions on the number of parameters to be evaluated, and the applicable scientific methods and standards are limited. The starting point in the design of this test protocol was therefore to create an optimal balance between reliable information that meets the demands of the different users and costs in terms of time and expenses for carrying out the tests.

2. Scope

This protocol specifies the information that is needed as a basis for an environmental verification of covers and other mitigation technologies for reduction of gaseous emissions from stored manure.

2.1. Definition of 'mitigation technologies for manure storage'

In general, there are two types of outdoor manure storage systems:

- Tanks or lagoons for slurry storage.
- Heaps or containers for solid manure storage.

Due to the different designs of these types of manure storage, there are also different designs for cover and other mitigation systems. The test design has to consider this.

In this protocol, a mitigation technology is defined as any treatment of manure that reduces emissions from stored manure, such as:

- Cover systems that reduce the contact area between the stored manure and the atmospheric air, e.g. a roof or floating covers.
- Additives, e.g. acidification.
- Compaction for solid manure storage.
- Any other treatment that reduces emissions.

2.2. Targeted results and information

The information specified includes:

- A comprehensive system description: working principle; system description; essential operation parameters, and user manual.
- Technical performance of the system based on data collected during the test period.
- Measurement methods including requirements, sampling strategy, data collection and handling, calculation methods, reporting.

- Evaluation parameters to assess the environmental performance of the system tested.
- Evaluation of operational stability of the technology.

The primary environmental pollutants focused on in this document are:

- Ammonia
- Odour
- Greenhouse Gases.

This protocol describes the requirements for testing covers and other mitigation technologies in a defined testing period. The test period and the number of sampling days are determined by the requirements for a statistically adequate evaluation of the cover performance. During the testing period the operational stability and deviations from normal operational functioning shall be observed and registered, and the observations reported in the test and evaluation report. Specific test parameters for the assessment of long-term operational reliability and durability will, however, not be included in this protocol.

Nevertheless, it is recommended that covers and other mitigation technologies should be re-evaluated three to five years after market introduction to assess the long-term effects and the durability of the technology, regardless of the fact that the present test protocol does not include specifications for such a re-evaluation.

2.3. Use of results for verification

After a test has been completed, verification of the environmental efficiency based on the test results can be carried out in accordance with this protocol and the General VERA Guidelines.

VERA does not endorse, certify or approve technologies!

VERA verifications are based on an evaluation of the technology's performance according to specific, predetermined criteria and the appropriate quality assurance procedures. VERA makes no expressed or implied warranties as to the performance of the technology and does not certify that a technology will always operate as verified. The end user is solely responsible for complying with any and all applicable federal, state, and local requirements. Further, the end user must be aware that the countries involved in VERA have different legal requirements, which will influence the status and use of this verification statement in each country.

3. Normative references

The referenced standards in the following text are indispensable for the application of this document. For dated references, only the edition cited applies. For undated references, the latest edition of the referenced document (including any amendments) applies.

4. List of abbreviations

a	Annus, Latin for year
C	Carbon
CH ₄	Methane
CO ₂	Carbon dioxide
DM	Dry matter
FTIR	Fourier transform infrared spectroscopy
GC-ECD	Gas chromatography – electron capture detector
GC-FID	Gas chromatography – flame ionisation detector
GHG	Greenhouse gases
GLP	Good Laboratory Practice
IVB	International VERA Board
IVC	International VERA Committee
LU	Livestock unit
N	Nitrogen
NH ₃	Ammonia
N ₂ O	Nitrous oxide
NO _x	Refers to NO (nitric oxide) and NO ₂ (nitrogen dioxide)
ppm	Parts per million
TAN	Total ammoniacal nitrogen (TAN=NH ₃ +NH ₄ ⁺)
VERA	Verification of Environmental Technologies for Agricultural Production

5. Terms and definitions

Additive (directly added)

A product or substance that is either manufactured or naturally occurring, which is added to manures with the purpose of modifying their biological, chemical or physical properties. Examples:

- Bacterial enzyme preparations
- Plant extracts
- Oxidising agents
- Disinfectants
- Urease inhibitors
- Masking agents
- Acid, acidifying compounds
- Adsorbents.

Ammonia (NH₃)

A gas derived from livestock manure by transformation of urea excreted by livestock or uric acid excreted by poultry and implicated in acidification and nitrogen enrichment of sensitive ecosystems.

Ammonia emission

The process by which ammonia gas (NH₃) is released from a solution.

Cover technology

Cover systems for manure storage facilities can be divided into cover systems that float on the manure surface – **floating covers** – and roof systems covering the manure storage facility – **roof systems**. See below.

Floating covers

Fabric membrane:

- floats directly upon the slurry surface. Water collected on the membrane needs to be pumped away.
- is suspended from the rim of the store and floats on the slurry surface. Water collected on the membrane needs to be pumped away.

Floating layer:

- natural crust, which may be formed by the content and residues of the slurry.
- chopped straw, which is applied upon the surface of the slurry.
- solid manure, which is applied upon the surface of the slurry.
- LECA pebbles, which are applied upon the surface of the slurry.
- granules or structures made of degradable or non-degradable floating elements, which are applied upon the surface of the slurry.

Roof systems (cover technology)

Tent roof:

Tent roofs have a central supporting pole with spokes radiating from the top. A fabric membrane is spread over the spokes and is tied to a rim-bracing. Tent roofs need to have ventilation openings to avoid risk of methane accumulations.

Rigid covers:

A rigid cover can be a flat deck or a conical roof. It is usually designed at the outset and is erected at the same time as the store. Flat deck is usually made of concrete, while conical roofs can be made of fibre glass. Flat deck usually has to be supported by bars.

Downtime

The period of time when the system tested is not operating as a result of malfunctions.

Greenhouse gases (GHG)

Gases that contribute to the 'greenhouse effect' and global warming. Carbon dioxide (CO₂), methane (CH₄) and nitrous oxide (N₂O) are the major greenhouse gases.

Liquid fraction

Liquid or thin fraction derived from the mechanical separation of slurry.

Manure

A general term denoting any organic material containing excreta from livestock which supplies organic matter to soils together with plant nutrients, usually in lower concentrations compared to inorganic fertilisers.

Slurry

Faeces and urine produced by housed livestock, usually mixed with bedding material and water during management. The dry matter content of slurry is usually in the range 1 – 10%. Slurry is a mixture of liquid and solid materials, where the majority of the solid material is typically undissolved in the liquid phase and therefore precipitates from the liquid during longer periods of storage.

Solid manure

Manure produced by housed livestock which is normally applied with a large amount of bedding material. Solid manure does not flow under gravity and cannot be pumped. There are several different types of solid manure arising from different types of livestock housing systems.

Standard error

Standard error (SE) of the mean is calculated as follows: $SE = SD/\sqrt{n}$, where standard deviation (SD) is calculated with the

equation $SD = \sqrt{\frac{\sum(X_i - \bar{X})^2}{(n - 1)}}$. If several measurements of gas emissions from a manure heap have been carried out

during the same time interval, one can calculate the SE of the average emission from this storage during the specified time interval. If emissions of ammonia during the same time interval has been measured from more than one manure storage containing manure from the same source and stored with the same technology, then one can calculate the SE of the average emission from this 'treatment' and use this SE in the assessment of significant differences between this treatment and another treatment.

Odour

Pleasant or unpleasant smell caused by different odorants with a wide range of chemical, physical, and biological properties. The odour concentration is generally given in European Odour Units per cubic metre air (OU_E/m³).

Uptime

The period of time when the tested system is in operation.

6. System description

The manufacturer/applicant is responsible for providing a precise and full description of the system or technology before initiation of a VERA test. This information must be provided because the data are required by the test institute, users of the system, verification authorities, etc. To some extent it also forms part of the final test report. The system description must include all relevant and essential information that is needed to:

- organise and design the test
- enable the farmer to operate, maintain and monitor the system properly
- where relevant, on-line monitor the system, including the key parameters needed for the determination of uptime/downtime of the system
- allow the verification authorities to check the system after a test has been carried out
- provide insights into working mechanisms of the system.

Different descriptions are required for covering systems and manure treatment systems (see tables below). The following two tables have to be completed before the test is initiated.

Table 1: System description of covering systems

Manufacturer	Name of company
Model	Model name and number
Description of performance	<ul style="list-style-type: none"> • Reduction of ammonia • Reduction of odour • Reduction of GHG • Other
Type of manure that can be covered by the technology	<ul style="list-style-type: none"> • Solid or liquid manure • Cattle, pig, poultry, or all types of manure • Treated manure, e.g. separated, digested or acidified manure types
Description of technology (Includes a short description of material and performance)	<ul style="list-style-type: none"> • Floating layer or floating granules of non- or slowly destructive materials, gas impermeable liquid floating on the surface or the like (describe material) • Tent (describe material) • Rigid cover (describe material)
Size and weight of the technology	<ul style="list-style-type: none"> • Weight (kg per area) • Thickness of material (mm) • Min/max area (m²)
Openings (only airtight materials)	<ul style="list-style-type: none"> • Area (m²) • Relative to total cover area (%)
Agitation (needed for stirring of the manure) and treatment of manure (taking place in the store)	<ul style="list-style-type: none"> • Mechanical • Use of additives • Other
Technical drawings	Should be specified on a separate page

Table 2: System description of manure treatment systems

Manufacturer	Name of company
Model	Model name and number
Description of performance	<ul style="list-style-type: none"> • Reduction of ammonia • Reduction of odour • Reduction of GHG • Other
Type of manure that can be handled by the technology	<ul style="list-style-type: none"> • Solid or liquid manure • Cattle, pig, poultry, or all types of manure • Treated manure, e.g. separated, digested, or acidified manure types
Description of technology (Include a short description of technology and performance)	<ul style="list-style-type: none"> • Ozonation • Acidification • Other additives (describe) • Other (describe)
Working principle	<ul style="list-style-type: none"> • Basic principle • Processes
Use of additives	<ul style="list-style-type: none"> • Type of additive • Amount of additive (kg/ton or m³ of manure) • Cost of additive at the time the test is conducted (cost per volume or weight)
Energy requirement	KWh per storage period and/or mass of manure
Technical drawings	Should be specified on a separate page

The **detailed description of the system or technology** to be tested must include the following.

- A list of the (technical) components needed for application, including type (e.g. material and characteristics), technical and functional description and design.
- A description of the technique applied, including the accuracy of application. The description must include the use of additives, composition of the additives, and their provision risk of pollution of the environment. The additives need be approved by national legislation.
- The system's function in detail and the expected performance of the system with respect to the effect on the pollutants.
- Illustrations and/or diagrams of the system (top and sectional views, details if necessary).
- A list of the essential design and operational parameters (ranges) that are specific to the system to be tested and that are decisive for proper function, and that should therefore be monitored during the test (e.g. minimum amount of additives applied per m³).

The manufacturer/applicant must provide general information about:

- detailed instructions on operation, service, maintenance and monitoring
- environmental and occupational safety of the products applied
- predicted durability of the system and its components
- warranty provisions.

User manual

A user manual for the technology must be available in the local language. It must be written in consideration of EN 82079 Preparation of instructions – Structuring, content and presentation, which provides general principles and detailed requirements for the design and formulation of all types of instructions, and Machinery Directive 2006/42/EC, which provides the regulatory basis for the harmonisation of essential health and safety requirements for machinery.

The user manual must include the information provided with the system description according to the descriptions above in this chapter and should in particular include instructions for the following.

- The operation of the system and the technical installations.
- The prevention and handling of incidents (environmental safety).
- Operational health and safety measures.
- Service and maintenance.
- Monitoring of the installations.

7. Requirements

This chapter specifies the requirements related to the testing of covers and other mitigation technologies for gaseous emissions from stored manure.

In addition, the chapter describes the measurement parameters to be included in the test and a specification of the methods to be used. Finally, the chapter includes requirements to ensure representative test conditions, and requirements related to the impact of the technology on occupational health and safety.

All more general requirements for the testing and verification procedures, including the qualification of test partners, are specified in the General VERA Guidelines (GVG).

7.1. Pre-testing or preparations for a full test of a technology

The test protocol can be used during the phases of developing a new technology (pre-testing) as well as for testing of a final technology (ready for sale) with the aim of verification.

It is strongly recommended to conduct pre-testing of a new technology before a final test is initiated, and to start a full test of a new technology only when the pre-test has shown its operational stability and that it is well-functioning. During pre-testing of a technology, parts of the test protocol can be used to clarify and optimise the performance and stability of the new technology. During such pre-testing of a technology, the manufacturer can visit the test facility any time.

However, during a full test of a technology with the aim of a VERA verification all the below mentioned requirements have to be fulfilled, including any general requirements stated in the GVG, requirements/restrictions on farm visits, and modifications of the technology.

The test of a technology involves various actors:

1. The applicant which intends to have a technology tested.
2. The test organisation which will conduct the required tests of the technology.
3. The farmer(s) who own the facilities where the tests are conducted.

A detailed **test plan** is to be elaborated by the test laboratory according to the template in Annex A including all relevant parameters. A log book must be included in the tests and the test plan could be presented in this book.

The applicant/manufacturer is responsible for providing a full description of the system or the technology to be tested prior to the start of a VERA test, cf. section 6. The description must include detailed instructions for operation, service, maintenance and surveillance.

7.2. Responsibilities during test period

During operation of the system, the applicant/manufacturer of the mitigation technology is responsible for electronic or manual logging of a number of key parameters to ensure the operation of the system. This logging shall include those parameters essential for the calculation of the uptime/downtime of the system, cf. section 6.

In the case of operational problems, these should be dated and described in the test log book by the farmer or the test organisation. In addition, a date and description should be included regarding when and how the problem is resolved. The log book should be signed by the farmer and the applicant/manufacturer when repairs have been finalised.

If the applicant/manufacturer has conducted tests on earlier models of the technology, all the previous test reports must be enclosed, including a description of the differences between the models.

The test organisation is responsible for coordinating and implementing the test plan and for drawing up all the necessary data record tables. Furthermore, the test organisation is responsible for the calculation of the uptime/downtime of the system tested, where relevant. The log book must be available to the test institute at any time during the test period.

The farmer is responsible for recording the production conditions in accordance with the test plan. The farmer must also record the time spent on operational problems and maintenance of the technology system.

7.3. Test design and sampling strategy

7.3.1. Test design

For both liquid manure (slurry) and solid manure systems a test of environmental storage technologies shall be performed according to the selected environmental parameters: ammonia, odour and/or GHG, as described below. All tests shall be performed as case-control studies, where the case system should only deviate from the control system by the environmental technology investigated.

The emissions of ammonia, odour and GHGs from manure stored by an environmental technology have to be related to a reference store method; for example, no cover but similar manure and storage design, in order to allow the calculation of the emission reduction efficiency of the environmental technology. The reference technology, which must be the most commonly used method in the nation concerned, must be described and specified.

Test facility

The mitigation technology must be tested under storage conditions that are as representative as possible of standard practice for storage of livestock manure, especially in terms of depth/height, volume, surface area etc. The minimum dimensions of a test facility must be:

- for liquid manure storages: at least 4 m³ slurry containers with at least 1.5 m depth
- for solid manure storages: at least 2 m x 2 m x 1.5 m (width x broadness x height).

If the technology is tested in small-scale designs, respecting the minimum dimensions given above, the test should be designed to allow complete comparability between small-scale and farm-scale storage facilities. This means that requirements need to be defined to ensure that both the design of the test facility and the management conditions during the test period are representative of the farm characteristics concerned.

7.3.2. Sampling strategy

Table 3: Sampling strategy during test of environmental storage technologies

Parameter	Requirement
Number of storage units for sampling	≥ 2 (minimum: 1 case and 1 control)
Minimum size of storage units	<ul style="list-style-type: none"> • Appropriate dimensions must be chosen. • Dimensions must be representative for the storage and explained in test report. • Measurements must cover the whole storage or parts of it depending on the measurement method (see Table 4).
Sampling periods	One in the period of spring/autumn (low emissions) One in the period of summer (high emissions)
Composition of manure	Solid manure: Three samples per storage unit, where each sample consists of ten representative subsamples. Liquid manure: Three samples per storage unit, if the manure is previously stirred and homogenised. Otherwise, three samples per storage unit, where each sample consists of ten representative subsamples.

Table 4 lists the sampling requirements when the measurements cover only parts of the storage. The VDI 3880:2011 section 5.3.2 ff ('passive area sources') can provide guidance.

Table 4: Sampling requirements if only partly covered

Sampling parameters	For measurement with partial covering
Number of sampling spots	100 m ² → minimum of 3 1000 m ² → minimum of 5
Size of sampling area under hood/canopy	At least 0.5 m ² surface exposed to flow.
Sampling duration	At least 30 min per sampling point.
Wind speed (in the centre of the canopy/hood):	0.1 – 0.3 m/s
Sampling lines	Condensation must be prevented, e.g. by heated tubes or higher ventilation rate.
Material	Non-sticky material to the gases which are investigated.
For ammonia measurements	If acid traps, avoid over-exposure (check with 2 flasks in a row).

Composition of the used manure

The data obtained by this protocol are limited to manure composed within specified limits that must be defined. The following manure component parameters (Table 5) therefore have to be measured and included in the test report.

Table 5: Composition of the livestock manure used in the test

Manure component	Unit	Measuring methods
Dry matter (DM)	g per kg (ww)	EØF 103°C
Total nitrogen	g per kg (ww)	Kjeldahl/Dumas
Ammoniacal Nitrogen (TAN)	g per kg (ww)	71/393/EØF
Ash content	g per kg (dry weight)	EØF 71/250
pH	pH units	GLP e.g. Metrohm, Porotrode
Source of manure	Cattle, pig, poultry, fur animals, etc.	
Type of manure	Solid, liquid, separated, acidified, digested, etc.	
Age of manure	Days of storage prior to measurement.	

Weather parameters

The data obtained by this protocol are highly depending on the weather and environmental conditions during the storage and sampling.

When using chamber systems, it is permissible to use data of the following parameters (Table 6) from the nearest meteorological stations (maximum 5 km from test site). When using Micromet, weather parameters must be measured at the site of the experiment and reported in the test report.

Table 6: Environmental and weather conditions during sampling

Climatic conditions	Unit
Time of year	Month
Wind speed	m s ⁻¹
Atmospheric humidity	RH
Air temperature	°C
Manure temperature in the surface liquid layer (0-5 cm) and in the middle of the storage	°C

7.4. Measurements

7.4.1. Calibration, verification and validation

For some measurement parameters, more than one measurement technique is listed in this VERA test protocol. These can be considered to be approved for use in a VERA verification. Some techniques are explicitly pointed out as '**standard reference method**', which shall be used to verify measurement data and validate other methods. Each configuration of a piece of measuring equipment has to be validated according to the reference method, specified in this protocol. The validation can be performed according to EN 14793 and has to be reported.

The calibration of measurement instruments is essential and a part of the definition of the configuration. This relates to calibration procedures which are only performed perennially or annually as well as for those which need to be carried out before each use. The calibration must also take into account possible cross-interference from other gases as well as temperature, relative humidity etc.

Verification, within the meaning of on-site control, of the measurement technique/equipment used must be performed on the test site in combination with a more precise measurement technique than the one used.

Any calibration and verification procedures and estimates of the measurement uncertainty for the relevant parameters must fulfil the requirements of ISO 17025 and be documented and reported.

7.4.2. Measurement parameters

Different sampling conditions and measuring systems must be employed for measurement of the different types of polluting gases. In Table 7, the required conditions and measuring methods for the measurements of ammonia, odour and GHG are listed.

Due to the lack of commonly accepted measurement methods for odour, a method is suggested but might not be accepted in all the participating countries.

Table 7: Sampling/measuring methods for the measurement parameters ammonia, odour and GHG

Parameter	Sampling (minimum requirements)	Measuring method
Ammonia	<p>Sampling methods: Continuous and simultaneous measurements of ammonia concentrations</p> <ul style="list-style-type: none"> • from inlet and outlet air (dynamic chamber) • air entering and leaving the periphery of the storage (Micromet method). <p>Length of sampling period: ≥ 60 days for solid manure. Take turning of the storage into account:</p> <ul style="list-style-type: none"> • If it is turned, measure continuously for 60 days. • If it is not turned, measure until the increase of accumulated emission over one week is less than 5%. <p>≥ 30 days for liquid manure types. In certain cases where the treatment may be affected by transformations longer periods might be needed.</p>	<p>Open dynamic chamber system covering the whole area, or part of it (see Table 4). Micromet (whole area). (Take care to prevent interferences).</p> <p>Standard reference method: Gas bubblers (ISO/DIS 21877, NEN 2826, VDI 3496).</p> <p>Other methods can be used after validation, e.g. photo-acoustic monitors, FTIR spectrometer.</p>
(Odour) *	<p>Sampling methods: Simultaneous sampling of the headspace of the chamber for determination of odour concentrations.</p> <p>Length of sampling period: Three sampling days per test.</p> <p>Number of samplings: Three samples of outlet air per treatment and sampling day.</p> <p>Sampling time: Between 20 and 60 minutes.</p> <p>Sampling equipment: Minimum 30 l nalophan bags.</p>	<p>* Note: This method might not be accepted in the Netherlands or Denmark. If improved standards are available and validated, they should be used instead.</p> <p>Flow-through sampling hood according to VDI 3880.</p> <p>Sampling methods that are in compliance with the VDI 3880 (for sampling) and CEN standard EN 13725/AC – Determination of odour concentration by dynamic olfactometric analyses.</p>
GHG	<p>Sampling methods:</p> <ul style="list-style-type: none"> • inlet and outlet air (for dynamic chambers) • the air of the headspace (for static chambers) or • air entering and leaving the periphery of the storage (for Micromet method). <p>Length of sampling period: ≥ 90 days for solid manure. ≥ 30 days for liquid manure types.</p> <p>Sampling frequency: Three times per week in periods where emission rates are expected to be high and twice per week in periods where emission rates are expected to be low.</p> <p>For checking the linearity when using the static chamber technology, there is an online calculator available at https://cran.r-project.org/package=HMR (Pedersen et al., 2010).</p>	<p>Static or dynamic chamber systems, Micromet.</p> <p>Standard reference method: Gas chromatography GC-FID (CH₄), GC-ECD (N₂O).</p>

7.4.3. Measurement methods

Open dynamic chamber system

For dynamic chambers, the air flow has to be measured on-site. The dynamic chambers may cover a part of the liquid surface, which in most cases will be the set-up if emissions from a large storage of liquid or solid manure is measured. If emissions from pilot-scale stores of animal manure are measured, then large chambers covering the entire manure store may be used. The principle of the mode of actions of the two methods are similar; therefore, a general description is given below.

The open dynamic chamber system consists of a canopy covering an area of part- or all-stored animal manure (referred to as the canopy section). The canopy is coupled to a metal duct containing a variable speed fan or a fan and a diaphragm shutter to regulate air flow, and an anemometer to record air flow through the tunnel. The air leaves the tunnel at the outlet of the metal duct. A section or a plate should be placed in front of the canopy to reduce the pulses of wind into the canopy. In the metal duct of the tunnels a honeycomb flow-straightener (air flow rectifier) may be installed in front of the axial fan to limit spiralling of the air flow created by the fan. Air flow in the metal duct is adjusted manually or automatically to mimic outside wind speed by changing the fan speed or diaphragm opening, and air is sampled within the metal duct with a multipoint sampler. See examples of dynamic chambers in Annex B.

NH₃ emission is expressed as F_{WT} (flux measured with dynamic chambers) in (kg N ha⁻¹ h⁻¹) and is calculated using the following equation:

$$F_{WT} = \frac{C_{NH_3,out} - C_{NH_3,in}}{A_B} A_i v_i$$

$C_{NH_3,out}$ and $C_{NH_3,in}$ are the time-averaged gaseous concentration of NH₃ (kg m⁻³) in outlet and inlet air, A_i is the cross-sectional area of the inlet (m²), v_i is the measured wind speed at tunnel inlet (m s⁻¹), and A_B is the source surface area covered by the tunnel canopy (m²).

Static chamber system (only for CH₄ and N₂O)

CH₄ and N₂O emissions can be measured using a closed chamber technique (Hutchinson and Mosier, 1981). Emissions of these gases are measured from the stored manure with chambers covering a part of the surface or the entire manure storage. The chambers must be gas-tight lids and the headspace stirred if the chambers are large, with a height more than 10–20 cm. Rubber septa for sampling with syringes are fitted to the chamber or air may be circulated through a continuous gas-measuring instrument by gas-tight tubes connected to out- and inlet ports of the chamber. If small chambers are used, these are placed or float on the manure surface during gas emission measurements. Changes in headspace CH₄ and N₂O concentrations are used for calculating gas fluxes and are calculated using the linear or logarithmic equation described by Hutchinson and Mosier (1981) or using the HMR package (Pedersen et al., 2010), which determines the best flux calculation method, i.e. linear regression or non-linear regression, based on the concepts of Hutchinson and Mosier (1981).

Micromet method

Micrometeorological techniques have the advantage of being able to measure emissions without disturbing the conditions of the manure storage. They can also be applied to a larger area than flux chambers, measuring the emissions from the whole manure storage without the need to scale up the measurement results. The following micrometeorological methods are adequate to measure emissions from manure storages.

- **Integrated Horizontal Flux (IHF) method.** In this method, a set of masts is placed upwind and downwind of the emission source. At different heights in every mast, both concentrations of the target gas (e.g. ammonia, methane, nitrous oxide) and meteorological parameters (e.g. wind speed, wind direction) need to be simultaneously measured. The difference between the horizontal fluxes through the vertical planes upwind and downwind of the source gives the emission from the emitting source. Measuring close to the source has the advantage of identifying concentrations that are usually high compared to background concentrations. Moreover, because the plume is not dispersed vertically, short masts are sufficient.
- **Tracer gas ratio method.** In this method, a tracer gas is released from the source at a known rate (E_{tracer}) in such a way that it mixes well with the emitted gases (such as ammonia or GHG). The concentrations of the tracer gas (C_{tracer}) and of the gas to be measured (e.g. ammonia; C_{NH_3}) are then measured downwind of the emitting source. Assuming that both

the tracer gas and ammonia disperse in the same way, the ammonia emissions from the source can be calculated from the ratio of the measured concentrations and the injection rate of the tracer gas according to the following equation:

$$E_{NH_3} = E_{tracer} \cdot \frac{C_{NH_3}}{C_{tracer}}$$

Table 8 provides a tool to aid in selecting the right methods for the respective storage types.

Table 8: Selection of methods for the respective storage types

	Static chamber	Dynamic chamber (e.g. floating system)	Micromet
Solid storage	Ok for GHG	Not suitable	Ok
Lagoons	Ok for GHG	Ok	Ok
Liquid storages	Ok for GHG	Ok	Ok

7.5. General aspects

7.5.1. Permitted deviation from the protocol

If it is known that the type of environmental technology tested does not reduce a specific parameter or has only a marginal effect on it, the manufacturer/applicant can decide to specify the pollution reduction for this specific parameter as zero without carrying out the prescribed measurements. However, the test report must show that in all probability, based on previous research, theories or test results, the environmental technology does not have any negative effect on the specific parameter.

7.5.2. Regulations, occupational health and safety

When performing a test according to this test protocol, all activities shall be carried out in compliance with relevant national and EU legislation in force, as well as relevant standards.

For cover technologies, there is no significant manual handling involved. Occupational health and safety or chemical regulations may not be relevant, whereas these issues are more likely to be relevant for manure treatment technologies like acidification. Special attention should be paid to the following considerations.

- **Occupational health and safety.** In general, all industrial machinery and equipment must comply with the Machinery Directive 2006/42/EC. They must be designed and constructed in such a way that they can be used, adjusted and maintained throughout all phases of their life without putting persons at risk.
- **Chemical regulations.** As there is no significant manual handling involved, this issue is not relevant for application technologies. The issue may be relevant for manure treatment technologies like acidification.

Lists of relevant EU directives as well as international standards within these fields are available in the bibliography of this test protocol and on the VERA website at <http://www.vera-verification.eu/en/technology-manufacturers/test-protocols/> under 'Links to EU directives and international standards'. Note that the list may not be exhaustive, and that national legislation and standards are not included.

7.6. Data treatment, calculation and evaluation of emissions

For each measurement parameter the necessary units expressing the results are specified to ensure the highest possible comparability of the results and a sufficient information basis for recalculating, reproducing, converting and relating of values.

The results of the emission parameters must be given per volume (m³), per surface area and per time (m⁻² d⁻¹). Together with the manure parameters, the emission results must be provided per mass per kg TAN or kg N.

The reduction rate between case and control shall be calculated for each individual measurement point and provided in tables with median, average and 95th percentile as well as standard error for both the summer and the spring/autumn period.

8. Test report and evaluation

This paragraph describes the requirements for the test report, including formalities for system and test description, data handling, statistical analysis etc.

The test report must be written in English and, if necessary, in the local language. The report must include chapters with the subheadings listed below. The following text gives a description of the contents that must be included in the chapters and suggestions on the contents of the individual sections.

Foreword

The foreword should include:

- a description of the three parties involved in the test – the applicant, the test institute and the farmer/s – and their respective roles during the test period
- specification of the test period, including dates
- date and signatures of the person(s) responsible for the test
- name and address of the test institute.

Introduction

The introduction must include a description of the applicant/manufacture involved in the test and give a general description of their mitigation technology. If the applicant/manufacture has performed previous tests, these must be described, and references provided.

Materials and Methods

The materials and methods section must include a description of the following.

- The technology, including photos and drawings.
- The manure involved in the test.
- The test design and dimensioning of the test.
- The measuring methods used and their measuring uncertainty, including an explanation of why they were used and a validation report, if other than the reference method.
- A specification of the measurement instruments used, the measurement points and the measurement frequency and calibration procedures.
- Description of calculation and statistical methods – including the statistical data processing method used, models and the statistical software package.

Results and discussion

The description of the results starts with a presentation of the mitigation technology efficiency, which is the primary target of the test.

The individual raw data shall be shown first in graphs and subsequently the processed data shall be given in tables.

After the presentation of the raw data, a discussion of the results shall be given. See Section 7.6 for guidelines on data treatment.

If the mitigation technique affects other parameters, these parameters must be measured and reported (e.g. pH changes in case of additives). The average and standard error of these parameters shall be shown in tables and commented on in the text.

Operational stability

An evaluation of the operational stability of the system must be given. This evaluation must be based on observations made during the entire testing period and must include all recorded data describing the stability of the system or technology. The uptime of the technology during the test period shall be calculated, as well as the efficiency of the technology corrected by the uptime factor. (Example: if the cleaning efficiency of a technology is 90% and the uptime is 80%, the corrected efficiency of the technology is 72%.)

Additional information

Furthermore, the test report must include an evaluation of the potential risks which may be related to the use of the system, including potential impact on:

- occupational health and safety
- other environmental issues
- if applicable, chemical regulations.

These evaluations shall include situations with normal operation of the technology system and any unforeseen uses and issues.

The test report shall include advice to the verification authorities on how to inspect the system.

Finally, the test report shall include an evaluation of how the results can be applied to other types of manure.

In cases where the verification body finds it necessary, the raw data must be made available by the applicant or the test institute for interpretation of the results and conclusions presented.

Conclusion

The conclusion presents a summary of the results (e.g. reduction rates of the primary parameters) for the different test periods with mean, minimum and maximum values, and validates the mitigation technology in general.

This section should only include conclusions that can be justified in the results section of the test report.

References

Relevant references must be specified.

Annexes

Annexes can be added if relevant.

9. Bibliography

Applied standards:

- **Directive 2006/42/EC** of the European Parliament and of the Council of 17 May 2006 on machinery and amending Directive 95/16/EC (recast).
- **ISO 4254-1** Agricultural machinery – Safety – Part 1: General requirements.
- **ISO 12100** Safety of machinery – General principles for design – Risk assessment and risk reduction.
- **EN 82079** Preparation of instructions – Structuring, content and presentation.
- **ISO/IEC 17025** General requirements for the competence of testing and calibration laboratories.
- **VDI 3880** Olfactometry – static sampling.
- **EN 13725** Air quality – Determination of odour concentration by dynamic olfactometry.
- **prEN ISO/DIS 21877** Stationary source emissions – Determination of the mass concentration of ammonia – Manual method.

References:

- Amon, B., Amon, T., Boxberger, J. and Alt, C., 2001. Emissions of NH₃, N₂O and CH₄ from dairy cows housed in a farmyard manure tying stall (housing, manure storage, manure spreading). *Nutrient Cycling in Agroecosystems*, 60(1–3), pp.103–113.
- Beauchamp, E.G., Kidd, G.E. and Thurtell, G.W., 1978. Ammonia volatilization from sewage sludge applied in the field. *Journal of Environmental Quality*, 7, pp.141-146.
- Amon, B., Amon, T., Boxberger, J., Pöllinger, A. and Zaussinger, A., 1996. Entwicklung einer Messeinrichtung zur Erfassung umweltrelevanter Gasemissionen. *Die Bodenkultur*, 47(4), pp.247-253.
- Braschkat, J., Mannheim, T., Horlacher, D. and Marschner, H., 1993. Measurements of ammonia emission liquid manure application: I. Construction of a windtunnel system for measurements under field conditions. *Journal of Plant Nutrition and Soil Science*, 156 (5), pp.393–396.
- Chadwick, D.R., 2005. Emissions of ammonia, nitrous oxide and methane from cattle manure heaps: effect of compaction and covering. *Atmospheric Environment*, 39, pp.787–799.
- Fillingham, M. A., VanderZaag, A. C., Burt, S., Balde, H., Ngwabie, N. M., Smith, W., Hakami, A., Wagner-Riddle, C., Bittman, S. and MacDonald, D., 2017. Greenhouse gas and ammonia emissions from production of compost bedding on a dairy farm. *Waste Management*, 70, pp.45-52. DOI: 10.1016/j.wasman.2017.09.013
- Hutchinson, G.L. and Mosier, A. R. 1981. Improved soil cover method for field measurement of nitrous oxide fluxes. *Soil Science Society of America Journal*, 45, pp.311–316.
- Lockyer, D. R., 1984. A system for the measurement in the field of losses of ammonia through volatilisation. *Journal of Science, Food and Agriculture*, 35, pp.837–848.
- Mosquera, J., van Dooren, H. J., Aarnink, A. A. and Ogink, N. W. M., 2010. Development of a fast measurement method for the determination of ammonia emission reduction from floor related measures. *XVIIth World Congress of the International Commission of Agricultural and Biosystems Engineering (CIGR), Quebec (Canada)*, June 13-17.
- Pardo, G., Moral, R., Aguilera, E. and Del Prado, A., 2015. Gaseous emissions from management of solid waste: a systematic review. *Global Change Biology*, 21, pp.1313–1327.
- Sommer, S. G. and Misselbrook, T. H., 2016. A review of ammonia emission measured with wind tunnels compared to micro-meteorological techniques. *Soil Use and Management*, 32, pp.101–108. DOI: 10.1111/sum.12209
- Sommer, S. G., Søgaard, H. T., Møller, H. B. and Morsing, S., 2001. Ammonia volatilization from sows on grassland. *Atmospheric Environment*, 35, pp.2023-2032.
- Webb, J., Sommer, S. G., Kupper, T., Groenestein, K., Hutchings, N.J., Eurich-Menden, B., Rodhe, L., Misselbrook, T.H. and Amon, B., 2012. Emissions of Ammonia, Nitrous Oxide and Methane during the Management of Solid Manures. *Sustainable Agriculture Reviews*, 8, pp.67-107, ISSN 2210-4410.
- Wood, J. D., VanderZaag, A. C., Wagner-Riddle, C., Smith, E. L. and Gordon, R. J., 2014. Gas emissions from liquid dairy manure: complete versus partial storage emptying. *Nutrient Cycling in Agroecosystems*, 99, pp.95-105. DOI: 10.1007/s10705-014-9620-2

Online calculator

Pedersen, A. R., Petersen, S. O. and Schelde, K., 2010. A comprehensive approach to soil-atmosphere trace-gas flux estimation with static chambers. *European Journal of Soil Science*, 61, pp.888–902.

Annexes

Annex A (informative): Template for a test plan

NAME OF TEST INSTITUTE

TEST PLAN FOR [technology/system]

[delivered from [name of manufacturer/applicant]]

CONTACT DATA

Type of technology	
Name and address of manufacturer/applicant	
Facility owner	
Address of owner	
Visiting rules	
Start of test (dd/mm/yy)	
End of test (dd/mm/yy)	
Name and address of test institute	
Responsible technician	
Technician(s)	
Consultant(s) from the test institute	
Contact person from the company financing the test	
Service technician(s) from the company	
File	

BACKGROUND AND AIM [maximum of one page]

A short description of the technology, in supplement to the description of Table 1 or Table 2. The development process of the system and any previous tests must be specified (all references must be included in the reference list at the end of the test plan).

This section must include a precise description of the aim of the test and a specification of the primary test parameters.

TEST PROCEDURE

The description of the test procedure must include the following items [in accordance with Section 7: Requirements]:

- Specification of the primary measurement parameters, e.g. ammonia.
- Specification of the measurement parameters describing the test conditions.
- Description of the locations of measurement points, instruments and how they are calibrated.
- Description of the work procedures.
- Timetable for the entire test period.
- Log book location and description of parameters to be recorded.

DATA RECORDING

The tables provided for recording data must be presented.

ALLOCATION OF RESPONSIBILITY

The allocation of responsibility must cover all working processes in the system/technology.

A list must be drawn up for each section and system/technology.

What needs to be done	When	By whom

PROCESSING OF RESULTS

Raw data shall be presented in tables, which shall be included in Appendices in the final test report. The raw data shall also be presented in graphs, which shall be included in the results section in the final test report.

The primary measurement parameters must then be analysed in accordance with the specifications given in the test protocol. The average and the standard deviation of reported emissions shall be calculated for both the reference and the environmental technology.

The measurement parameters shall be analysed in order to determine whether the emissions from the storage facility with an environmental technology are statistically different from the emissions from the reference storage facility.

APPENDICES

The appendices must include all data recording tables, e.g. tables for ammonia recordings and reference technology.

UPDATES TO THE TEST PLAN

The test plan must be updated every time changes are made. It is not sufficient to merely list the changes in the log book. For each update, the date of the changes must be noted, and the test plan must be assigned a new version number.

Example:

1st version: DD/MM/YY Initials 1 / Initials 2

2nd version: DD/MM/YY Initials 1 / Initials 2

Annex B (informative): Examples of dynamic chambers

The VDI 3880:2011-10 describes a 'Flow-through hood' in detail, with inlet and outlet fan and sampling points at inlet and outlet.

The standard dynamic chambers (Figure 1) used in most studies consist of a transparent canopy (2 m long, 0.5 m wide and about 0.4 m high) covering the treated ground area (referred to as the canopy section), coupled to a metal duct containing a variable speed fan and an anemometer to record air flow through the tunnel.

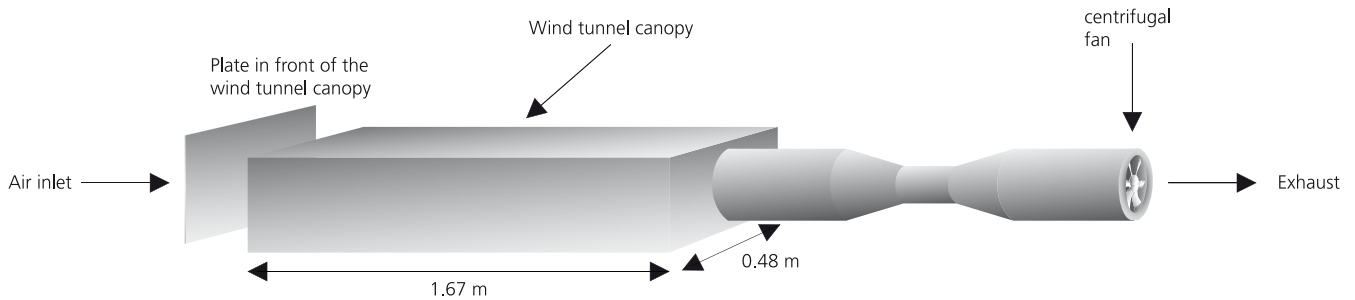

Figure 1: Dynamic chamber with plate

The air leaves the tunnel at the outlet of the metal duct. In the metal duct of the tunnels designed by Lockyer (1984), a honeycomb flow-straightener (air flow rectifier) is installed in front of the axial fan to limit spiralling of the air flow created by the fan. Air flow in the metal duct is adjusted by manually changing the fan speed, and air is sampled within the metal duct with a multipoint sampler. A plate is placed at the opening of the steel duct with the aim of reducing influences of variation in ambient wind speed on air flow through the dynamic chambers. To reduce the effect of fan movement on the air flow in the canopy, the length of the steel duct may be increased.

The alternative to a plate behind the dynamic chamber may be a narrow inlet opening (Figure 2) or an elevated air inlet (Figure 3), which also contribute to reducing interference of NH_3 emitted from neighbouring plots.

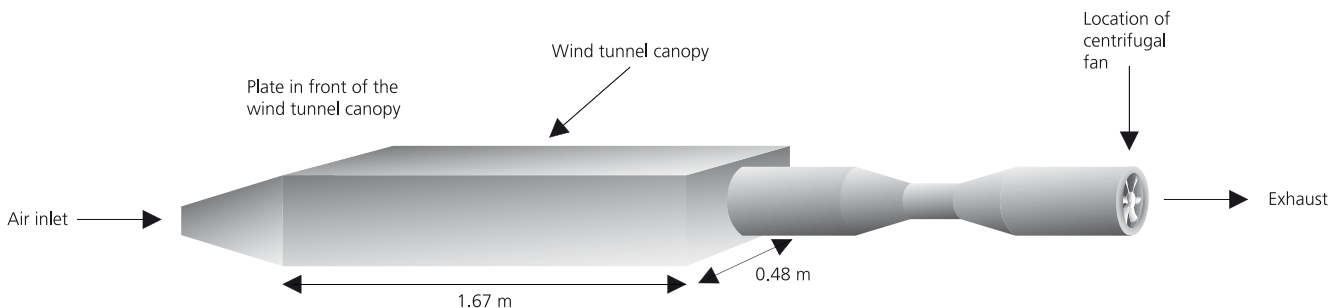

Figure 2: Dynamic chamber with narrow inlet

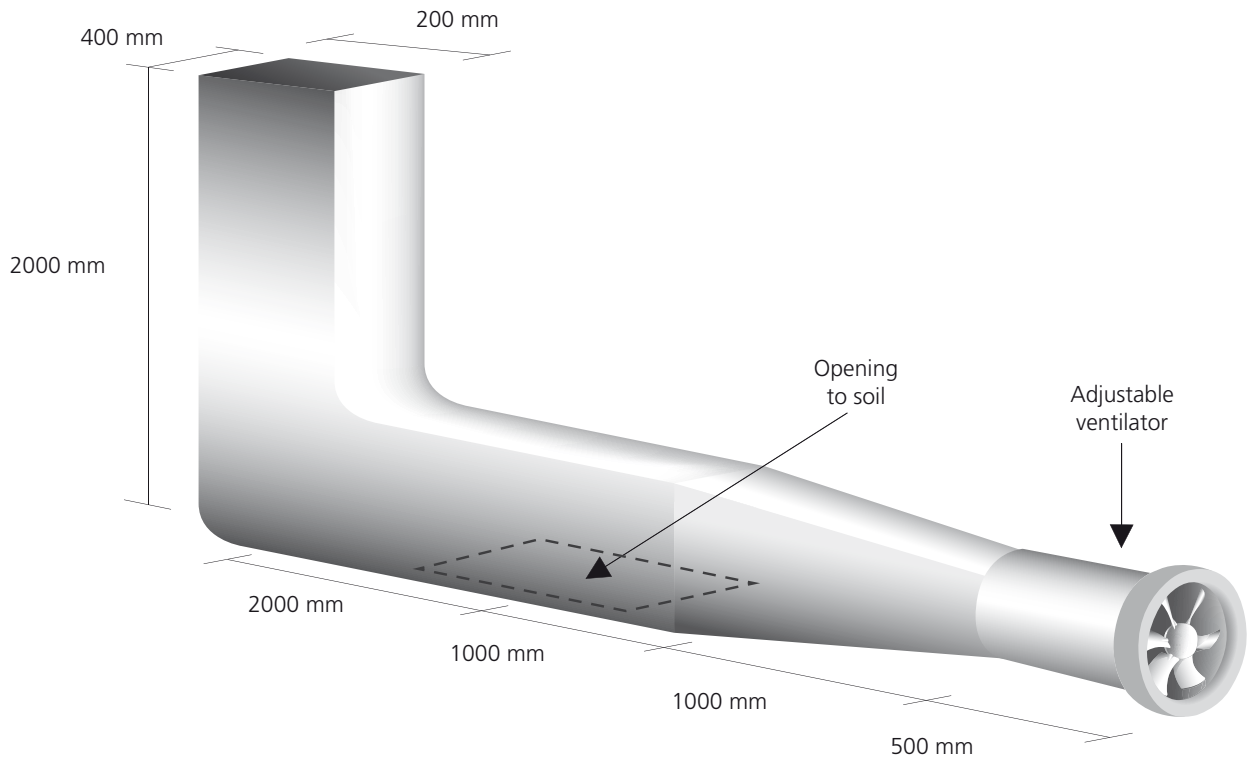

Figure 3: Dynamic chamber with elevated air inlet

Figure 4 depicts a dynamic chamber, which includes a section with an air flow straightener positioned before the canopy and an air flow straightener between the fan and the canopy, with air mixing by the fan to ensure representative gas sampling.

Air flow through the dynamic chamber may be adjusted using the fan or by changing the circular opening area of a diaphragm shutter between the canopy and the fan.

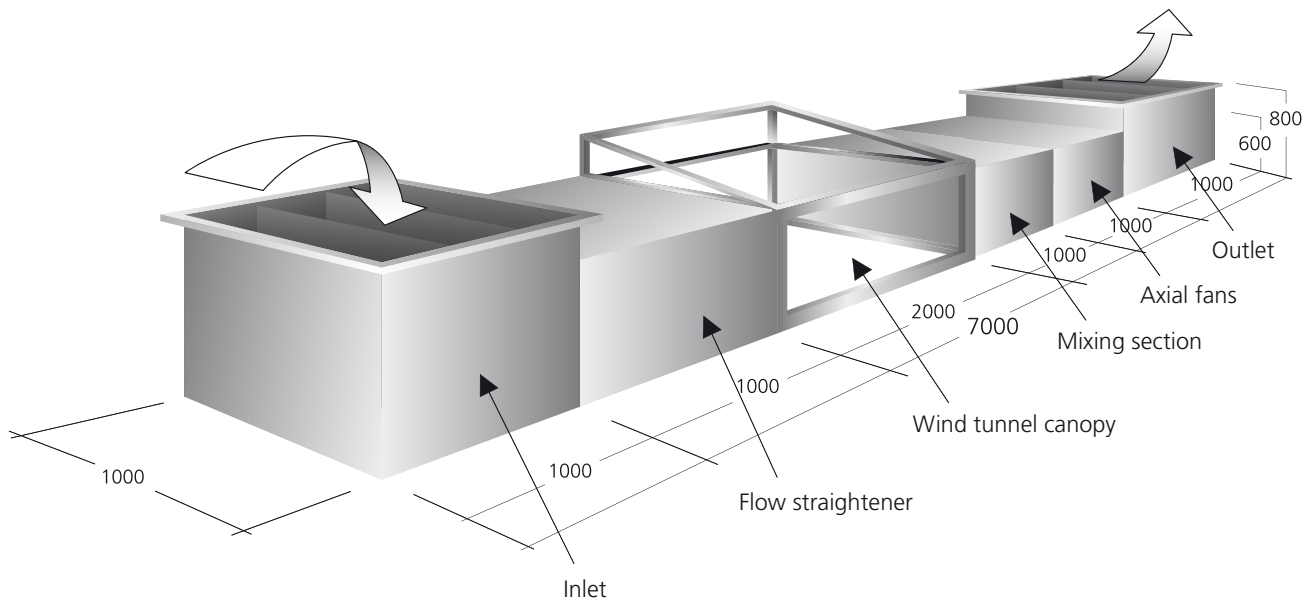

Figure 4: Dynamic chamber with air flow straightener

(Drawings are inspired by dynamic chambers presented in Lockyer (1984), Braschkat et al. (1993), Sommer et al. (2001).)